

 **POWERTEC®**

**STRENGTH**

**L-SC13**

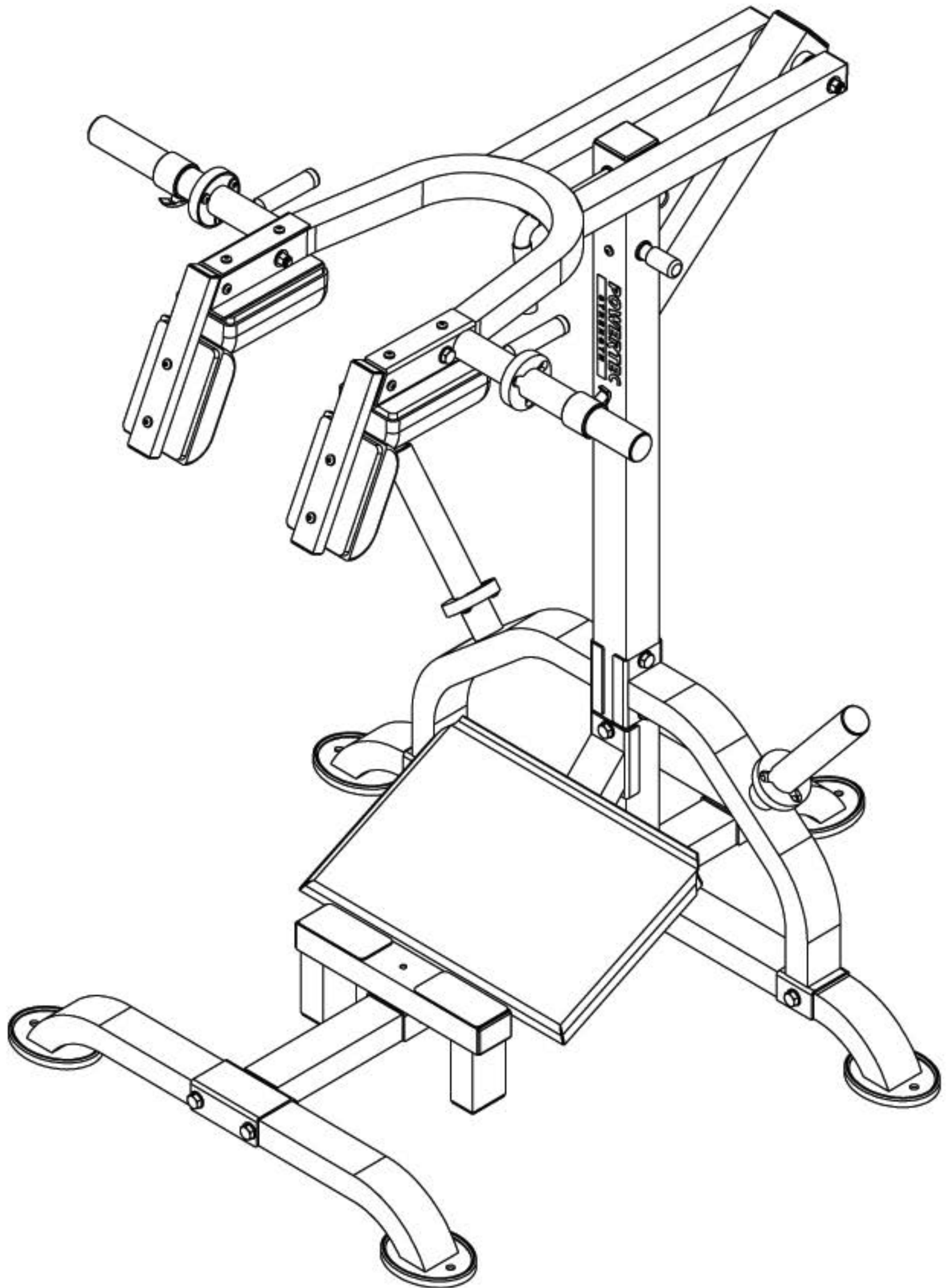

**LEVERGYM SQUAT CALF**

**Manual**



**Thank you for purchasing your new Powertec equipment.**  
**To maximize the use of this equipment, please take a moment to study, understand and familiarize with the assembly instructions and follow the sequence of steps as provided in the manual.**

**Because of our products unique features, this manual was created to provide you with information on how to assemble and properly maintain your equipment.**

**Table of Contents**

Introduction and Weight Capacities..... 2  
 Safety Instructions, Warnings and Cautions ..... 3  
 Maintenance Tips..... 4  
 Tools Required for Assembly..... 5  
 Hardware List..... 6  
 Parts List..... 7  
 Exploded Diagram..... 8  
 Assembly Steps..... 9 - 12  
 Featured Exercises..... 13  
 Warranty Certificate..... 14  
 Warranty Registration Card..... 15

**L-SC13 Levergym Squat Calf**

**Weight Capacities**

Squat Lever Arms: 500 Lbs.

**Featured Exercises**

Machine Squats                      Calf Raises

**Recommended Strength Classic Systems**

- |          |                             |          |                      |
|----------|-----------------------------|----------|----------------------|
| L-CDA+13 | Levergym Chin/Dip Assist    | L-CG13   | Levergym Compact Gym |
| P-BT13   | Basic Trainer               | P-LM13-S | Powertec Lat Machine |
| P-CLS13  | Compact Leg Sled            | P-LP13   | Powetec Leg Press    |
| OP-255N  | Olympic Plates 255 Lbs. Set |          |                      |

## SAFETY INSTRUCTIONS, WARNINGS AND CAUTIONS



It is recommended that users of this equipment receive a thorough medical exam before commencing any exercise program. This is especially important if you have never Exercised and or are over the age of 35, are pregnant or suffer from any health issues.

### **Read All Warnings and Cautions on this Manual and on the Product**

**This product should only be used after a thorough review of the Owner's Manual.**

**Keep children away from the product when in use.**

**Set up and operate the product on a solid level surface.**

**Do not set up the product on loose rugs or uneven surfaces.**

**Make sure adequate space is available to exercise and move around the product.**

**Inspect product before and after each use, inspect for worn out or loose parts, repair or replace as needed.**

**This equipment meets industry safety standards for stability when used for the intended exercise. Do not allow straps, resistance bands or other means to be attached to the framework of this equipment to perform stretching or body weight exercises as it can result to equipment instability and lead to serious injuries.**

**Always choose a workout that best fits your needs, physical strength and flexibility Levels, know your limits and your product limits and train within them.**

**Always wear proper footwear with nonskid rubber soles such, running, walking or Cross training shoes that fit well and provide support.**

**Do not exercise bare foot or in socks.**

**Always use common sense when exercising.**

  
**POWERTEC**<sup>®</sup>



## MAINTENANCE



The safety and performance of this product can be maintained only if it is examined regularly for damage and normal wear. Examine the equipment before each use for damage and wear. Replace damaged and worn components immediately or put the equipment out of use until repaired.

### **Inspect Daily / Before Each Use!**

Inspect system. Make sure it is in good condition and operates smoothly. If you find damage, **DO NOT USE**. Contact your authorized Powertec dealer or Powertec Customer Service Center for assistance.

### **Inspect Daily / After Each Use!**

Clean system with a clean, dry cloth. Use a mild detergent or spray on upholstery. Do Not use cleansers containing enzymes.

### **Inspect Weekly!**

Clean your system fully with a clean and ammonia based cleaner. Touch up any scratches with touch-up paint to prevent rust, if necessary.

### **Inspect Monthly!**

Examine the frame for signs of cracking or permanent bending. Do not use the equipment if you see this. Contact Powertec Customer Service Immediately. If you have any questions on the correct use or maintenance of this equipment, call your authorized distributor or Powertec Customer Service at 800-250-6665

### **Our Customer Service Mission:**

*“Committed to Stronger Lives”*

By providing friendly and understanding service.

## Tools Required for Assembly



**M6 Allen Wrench**



**Wrenches**  
13 mm = 1/2"  
19 mm = 3/4"  
21 mm = 13/16"



**8" Adjustable Wrench**

# HARDWARE LIST



Part No. 23 Hex Bolt 3/8" x 3/4"



Part No. 25 Hex Bolt 3/8" x 2 3/4"

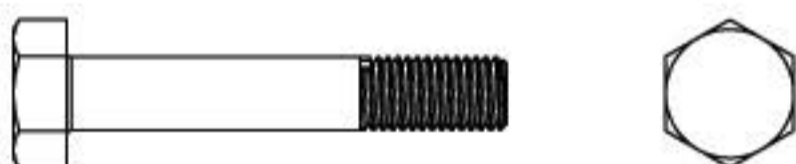

Part No. 27 Hex Bolt 1/2" x 3"

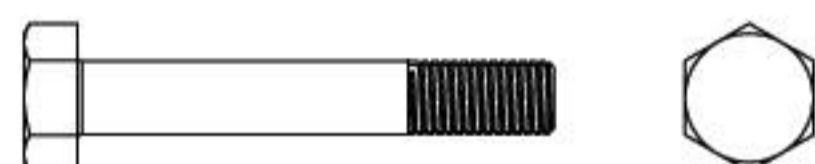

Part No. 28 Hex Bolt 1/2" x 3 1/4"



Part No. 26 Hex Bolt 1/2" x 2 3/4"

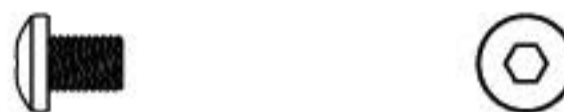

Part No. 32 Hex Bolt 3/8" x 1/2"



Part No. 24 Hex Bolt 3/8" x 1 1/2"



Part No. 31 Washer 1/2"



Part No. 30 Nylon Nut 1/2"



# PART LIST

 **POWERTEC**<sup>®</sup>

<u>Part#</u>	<u>Description</u>	<u>Qty</u>
1	Linkage Tube	1
2	Front Base Tube	1
3	Rear Base Tube	1
4	Upright	1
5	Tilted Support Tube	1
6	U Shape Arm	1
7	Support Tube (R & L)	2
8	Foot Support Tube	1
9	Shoulder Pad Tube L	1
10	Shoulder Pad Tube R	1
11	Angle, Back Pad Tube	2
12	Linkage Plate	1
13	Foot Plate	1
14	Safety Bar	1
15	Weight Horn	4
16	Rubber Bumper	4
17	Safety Tube	1
18	Bumper	2
19	Big Shoulder Pad	2
20	Small Back Shoulder Pad	2
21	Steel Axis	1
22	Collar	2
23	Hex Bolt 3/8" x 3/4"	4
24	Hex Bolt 3/8" x 1 1/2"	7
25	Hex Bolt 3/8" x 2 3/4"	5
26	Hex Bolt 1/2" x 2 3/4"	1
27	Hex Bolt 1/2" x 3"	2
28	Hex Bolt 1/2" x 3 1/4"	2
29	Hex Bolt 1/2" x 4"	13
30	Nylon Nut 1/2"	19
31	Washer 1/2"	37
32	Hex Bolt 3/8" x 1/2"	12

**L-SC13**

**LEVERGYM SQUAT CALF**

# EXPLODED DIAGRAM

 **POWERTEC**®

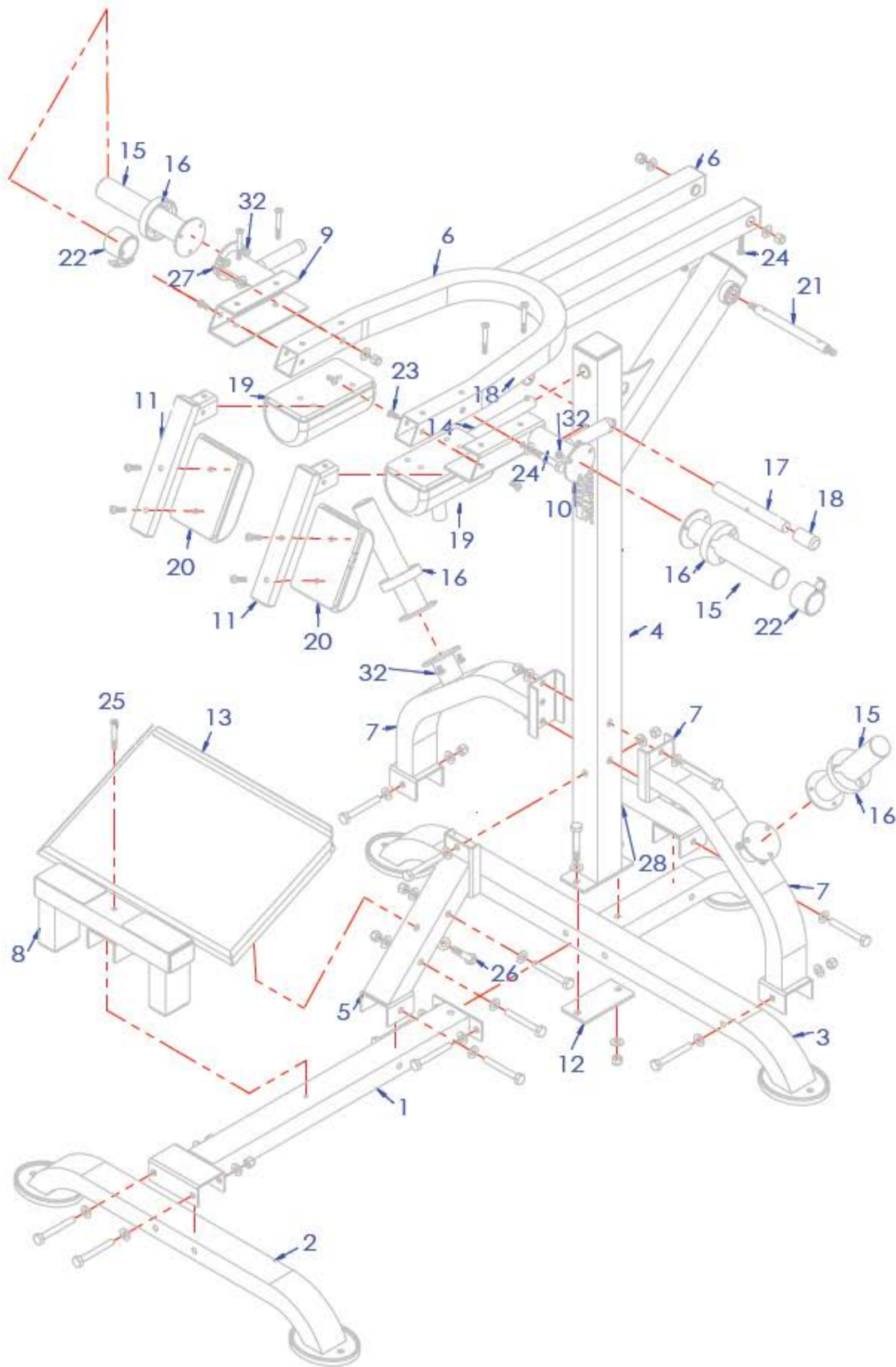

**L-SC13**

**LEVERGYM SQUAT CALF**



# ASSEMBLY ONE

**POWERTEC**<sup>®</sup>

## Step 1

Connect Linkage Tube No. 1 To Front Base No. 2 and Rear Base Tube No. 3 using Hex Bolt No. 29, Washers No. 31 and Nut No. 30.

## Step 2

Install Upright No. 4 on to Rear Base Frame No. 3 using Linkage Plate No. 12 under the Rear Base Frame, use hardware:

Hex Bolt No. 28, Washer No. 31 and Nut No. 30

Install Tilted Support Tube No. 5 to Upright No. 4 use Hex Bolt No. 29, Washer No. 31 and Nut No. 30

## Step 3

Install Safety Tube No. 17 on to Upright No. 4 use Hex Bolt No. 24 to secure it and add Bumpers No. 18 at each end of part No. 17.

Install Safety Bar No. 14 to the top of Upright No. 4

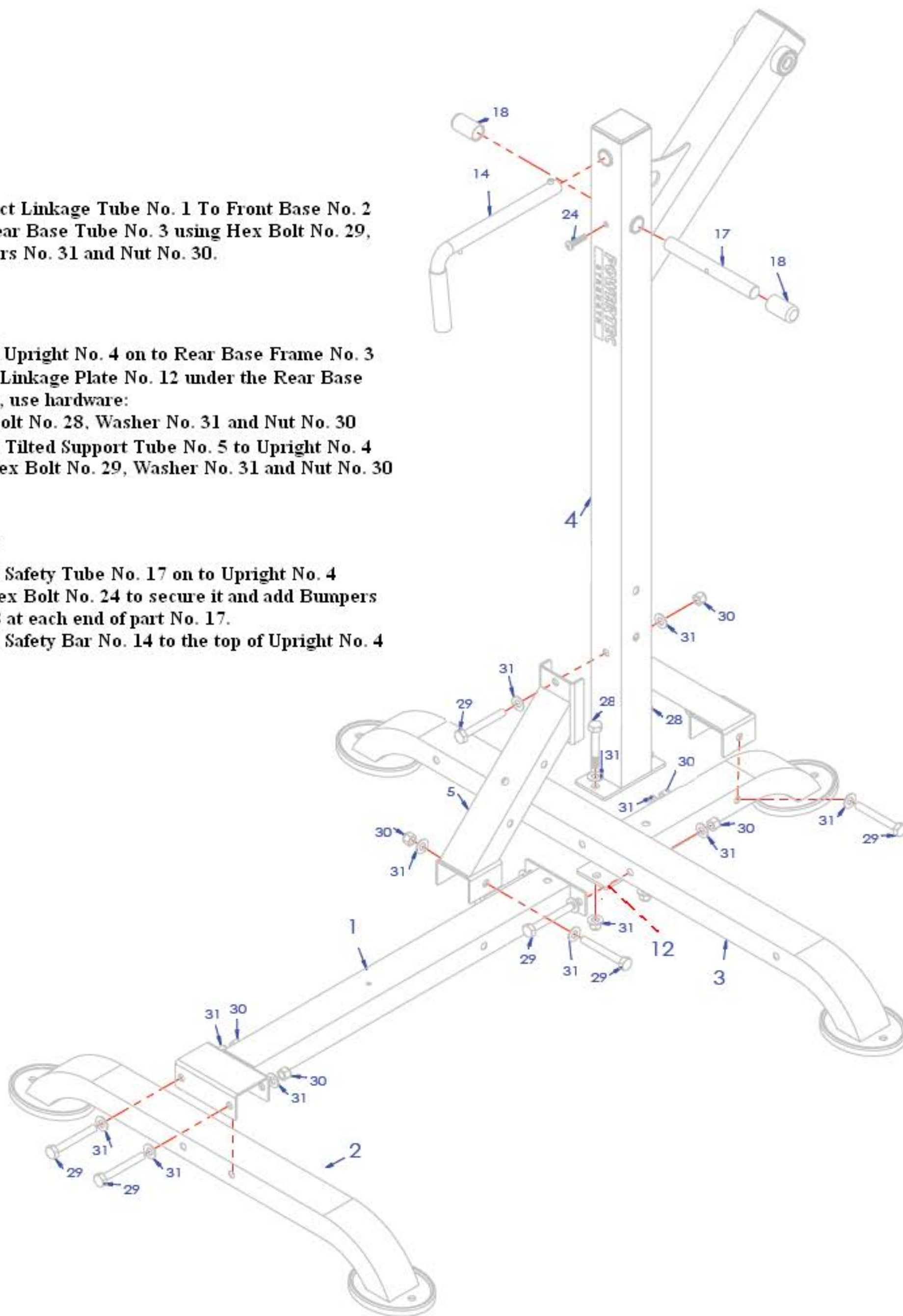

**L-SC13**

**LEVERGYM SQUAT CALF**

# ASSEMBLY TWO

**POWERTEC**<sup>®</sup>

## Step 1

Install Support Tubes No. 7 to Rear Base Tube No. 3 and Upright No. 4, use Hex Bolt No. 29, Washer No. 31 and Nut No. 30.

## Step 2

Install Foot Plate No. 13 to Tilted Support Tube No. 5 using Hex Bolt No. 26 and No. 26, Washers No. 31 and Nut No. 30.

## Step 3

Install Foot Support Tube No. 8 to Linkage Tube No. 1 use Bolt No. 25.

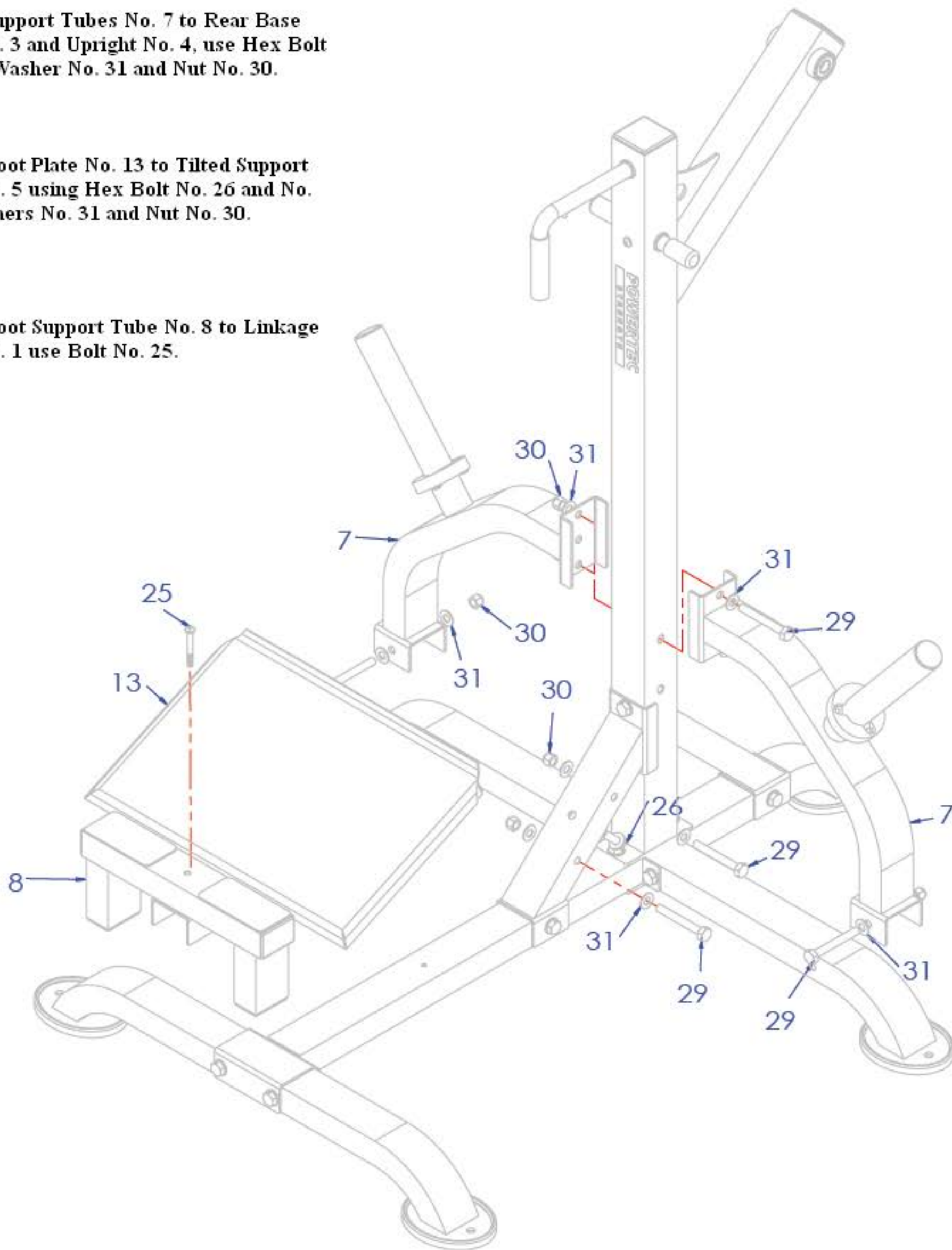

**L-SC13**

**LEVERGYM SQUAT CALF**



# ASSEMBLY THREE

 **POWERTEC**<sup>®</sup>

## Step 1

Install U Shape Arm No. 6 on to Upright No. 4 using Steel Axis No. 21, and Washers No. 31 and Nut No. 30, use Bolt No. 24 under the Frame to secure Steel Axis on th No. 4 Upright!

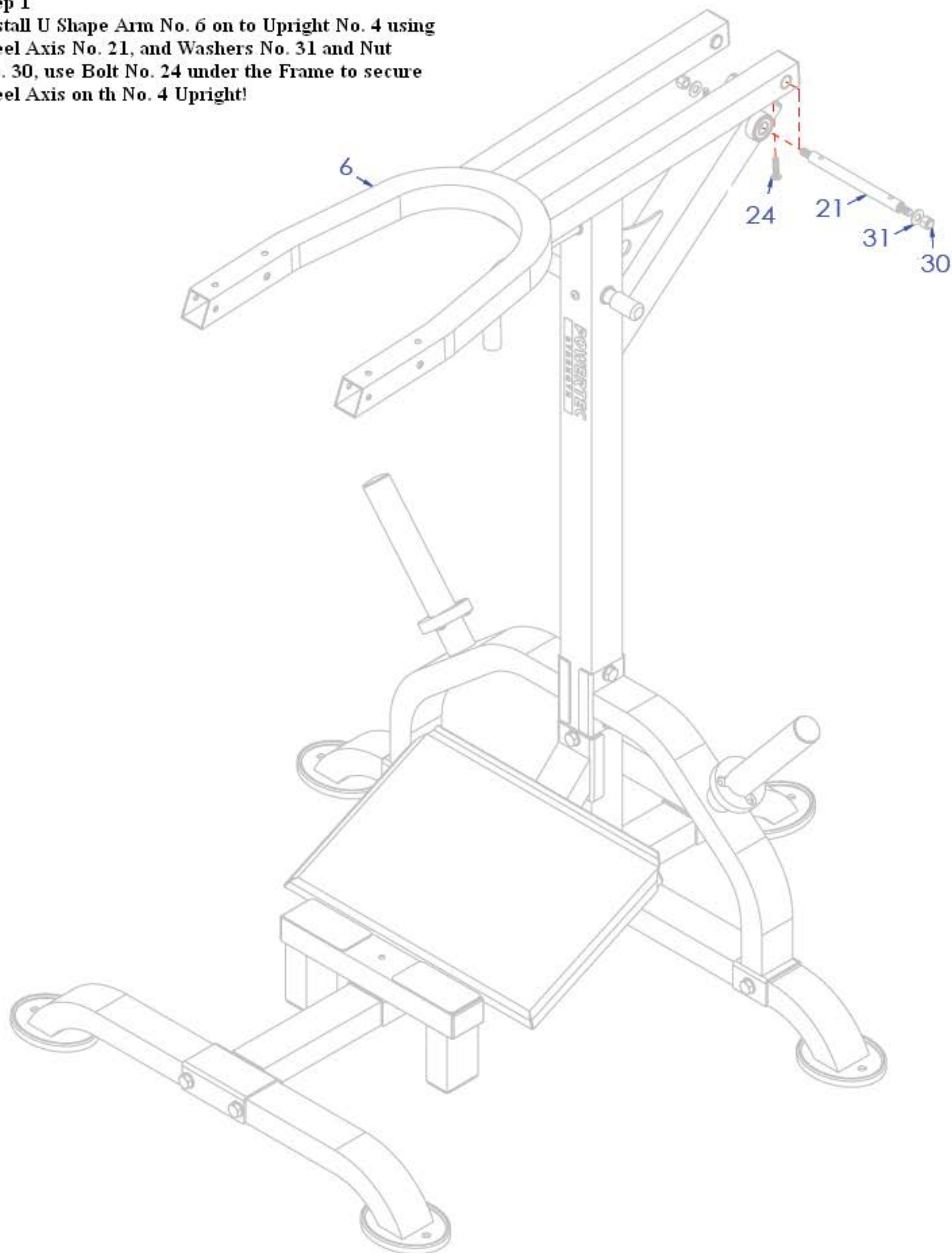

**L-SC13**

**LEVERGYM SQUAT CALF**

# ASSEMBLY FOUR

  
**POWERTEC**<sup>®</sup>

## Step 1

Install Shoulder Pad Tubes No. 9 and No. 10 Accordingly (Left and Right).  
Use Hex Bolts No. 23 and No. 27 with Washers No. 31 and Nut No. 30.

## Step 2

Install Small Back Pads No. 20 using Hex Bolts No. 24  
Install Big Shoulder Pad No. 19 using Hex Bolts No. 25

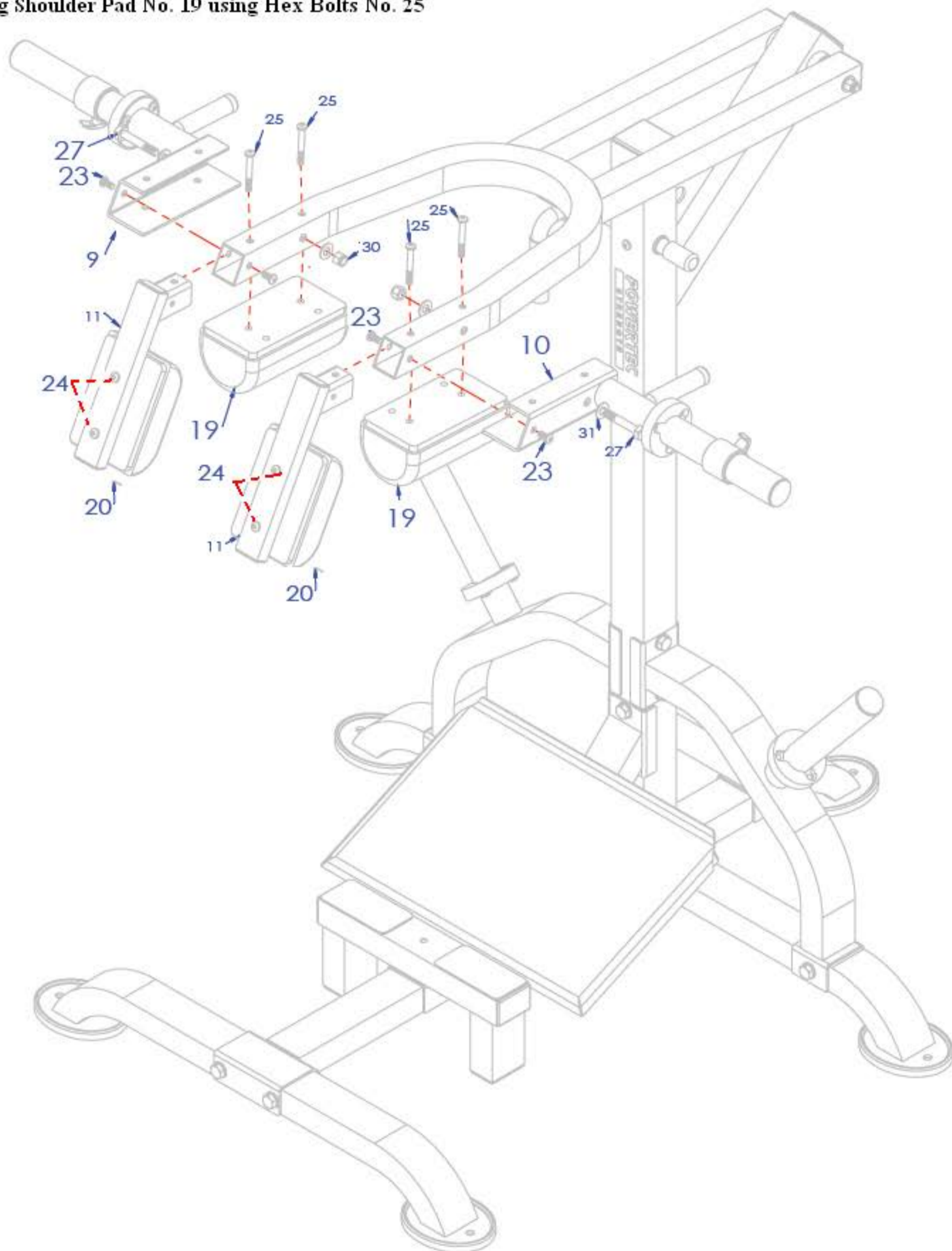

## Note;

Weight Horns No. 15 can be installed using Bolts No. 32

**L-SC13**

**LEVERGYM SQUAT CALF**



## LEVERGYM SQUAT CALF



**Calf Raise**

Facing the machine, position yourself so that the pads are resting comfortably on your shoulders.

Grip the handle bars with your palms facing each other.

Raise your heels by slowly rising on the balls of your feet, until your ankles are fully extended. keep your back and knees straight, do not allow your feet to rotate or roll.

Pause briefly before returning to starting position.



**Machine Squat**

Facing the machine, position yourself so that the pads are resting comfortably on your shoulders. Grip the handle bars with your palms facing each other. Your feet should be firmly planted on the platform, shoulder width apart.

Bend your knees until they are inline with your toes, do not extend past your toes.

Pause briefly before returning to starting position.

# WARRANTY

**Serial No.**

Thank you for purchasing one of Powertec's products.

Powertec warrants that the Product you have purchased is free from defects in materials and workmanship.

Powertec offers a Lifetime Warranty on Structural Frame.(Excludes Surface Finish).  
5 year warranty on Moving Frames (Press Arms and other unspecified moving components).  
Two year warranty on Components (Bearings, Locking Pins, Pulleys, Cables, Slide Rods).  
One year warranty on Pads, Grips and other unspecified parts.

- All parts are shipped free of charge for first 90 days of date of purchase.
- Warranty is to original purchaser only (excluding dealer). Warranty is not Transferable in the event you sell the product.
- Warranty claims are subject to inspection and are voided if equipment shows Signs of abuse or alterations made other than the ones recommended by Powertec.
- Missing parts must be reported within 30 days from receipt of unit(s).
- Proof of purchase is required; your sales receipt must show date of purchase.
- For more information on the warranty or to obtain warranty service, please contact The appropriate Powertec Customer Service Department in the USA or Europe.

Powertec Inc. USA  
2100 E. Artesia Boulevard  
Long Beach, CA. 90805 – USA

Powertec Europe  
6, Rue de l'Europe  
68500 Bergholtz - France

**Phone:** (800) 250-6665  
**E-mail:** [service@powertecfitness.com](mailto:service@powertecfitness.com)

**Phone:** + 33 (0) 3 89 62 56 30  
**E-mail:** [contact@powertec-europe.fr](mailto:contact@powertec-europe.fr)

Thank you for giving us the opportunity to fulfill your strength and fitness needs.

## **POWERTEC®** Customer Warranty Information Sheet

Last Name: \_\_\_\_\_ First Name: \_\_\_\_\_

Company: \_\_\_\_\_

Street Address: \_\_\_\_\_

City: \_\_\_\_\_ State: \_\_\_\_\_ Zip Code: \_\_\_\_\_

Daytime Telephone No: \_\_\_\_\_ Alternate Telephone No. \_\_\_\_\_

E-Mail: \_\_\_\_\_ Date of Purchase: \_\_\_\_\_ Purchase Price: \_\_\_\_\_

Dealer Name and Address: \_\_\_\_\_

Model Name & Code: \_\_\_\_\_ Optional: Male / Female: \_\_\_\_ Age: \_\_\_\_ Occupation: \_\_\_\_\_

POWERTEC IS NOT LIABLE IF THE TRAINER SHOULD INJURE THEMSELVES WHILE USING POWERTEC EQUIPMENT OR WHILE PERFORMING THE TRAINING ROUTINE



COMMITTED TO STRONGER LIVES<sup>®</sup>

**POWERTEC INC.**  
2100 East Artesia Boulevard  
Long Beach, CA. 90805 - USA

Phone: (800) 250-6665  
Fax: (714) 908-0493  
service@powertecfitness.com  
www.powertecfitness.com

**POWERTEC EUROPE**  
6, Rue de l'Europe  
68500 BERGHOLTZ - France

Phone: + 33 (0) 3 89 625 630  
Fax: + 33 (0) 3 89 625 631  
E-mail: contact@powertec-europe.fr

Return Warranty Registration Card to Appropriate Powertec Address:



---

---

---

Place  
Stamp  
Here



---

---

---





Squat calf

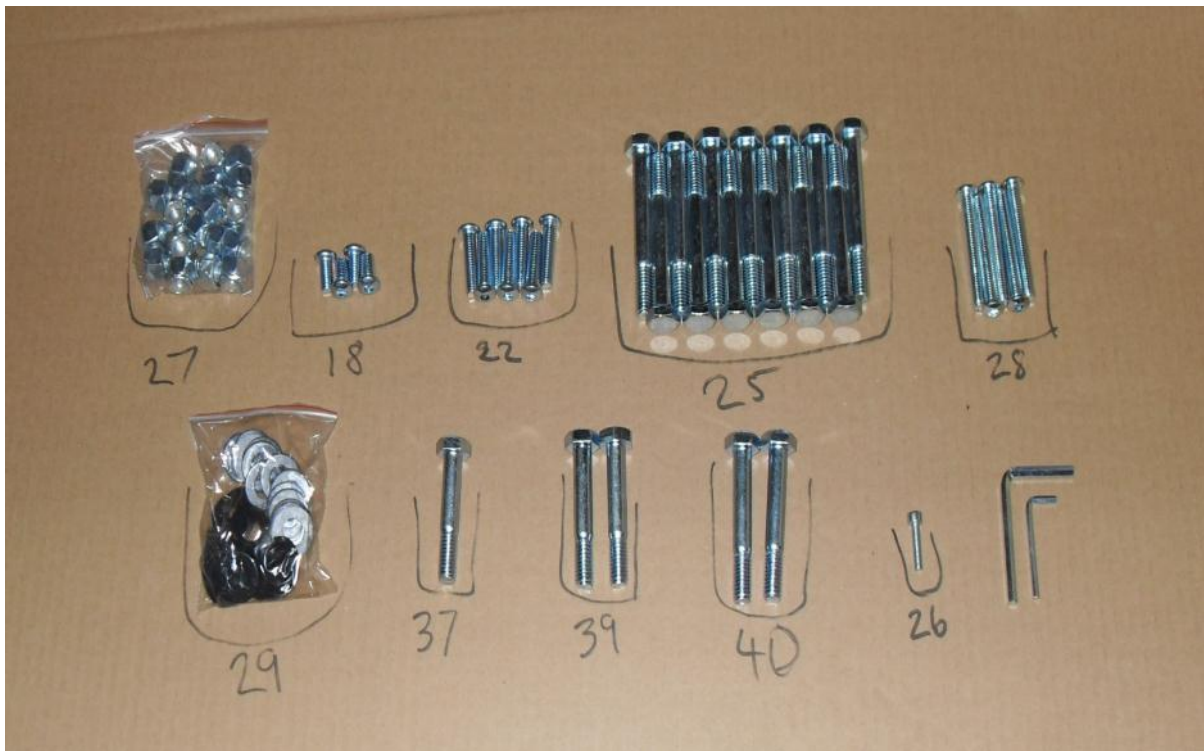



Assembly 1









Prop the base up to put bolts under the base frame







Assembly 2



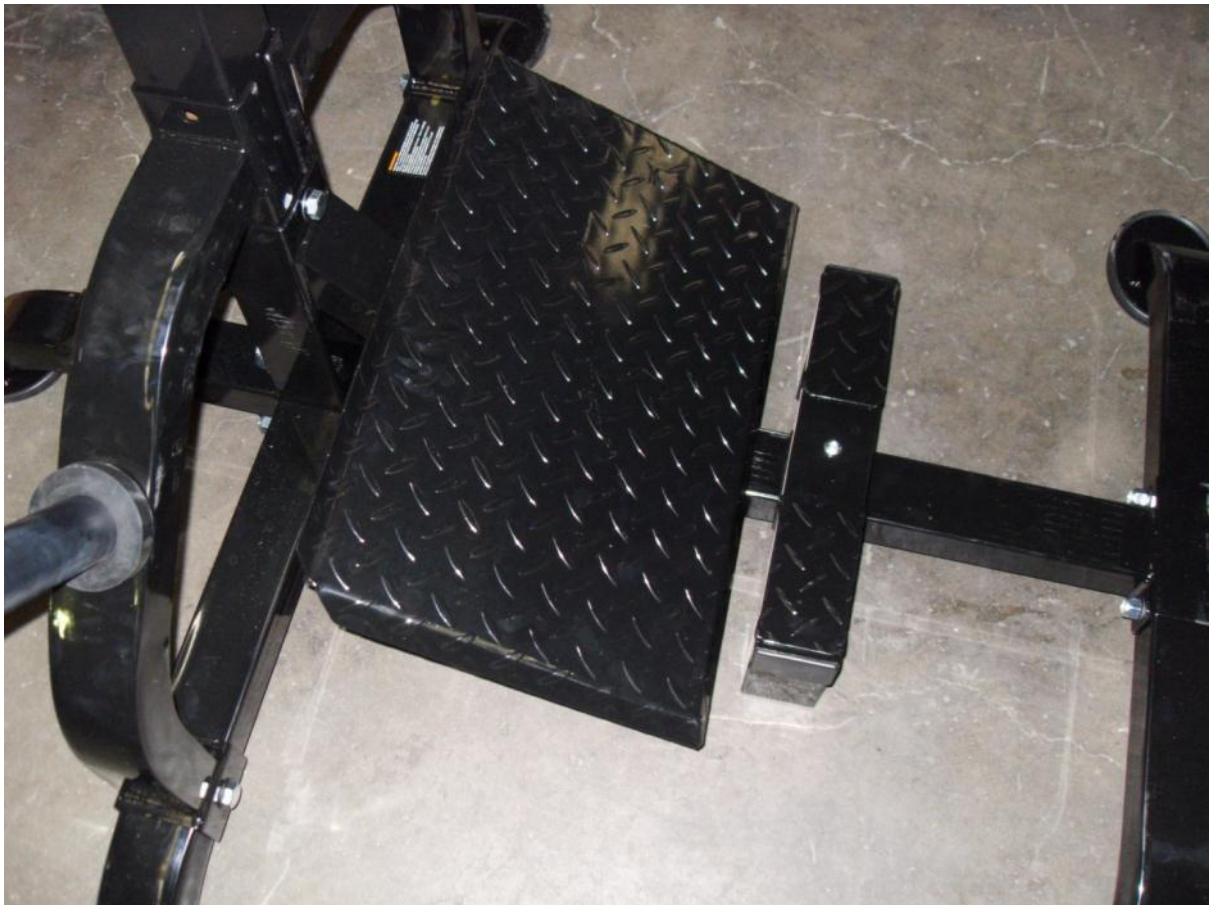



Assembly 3

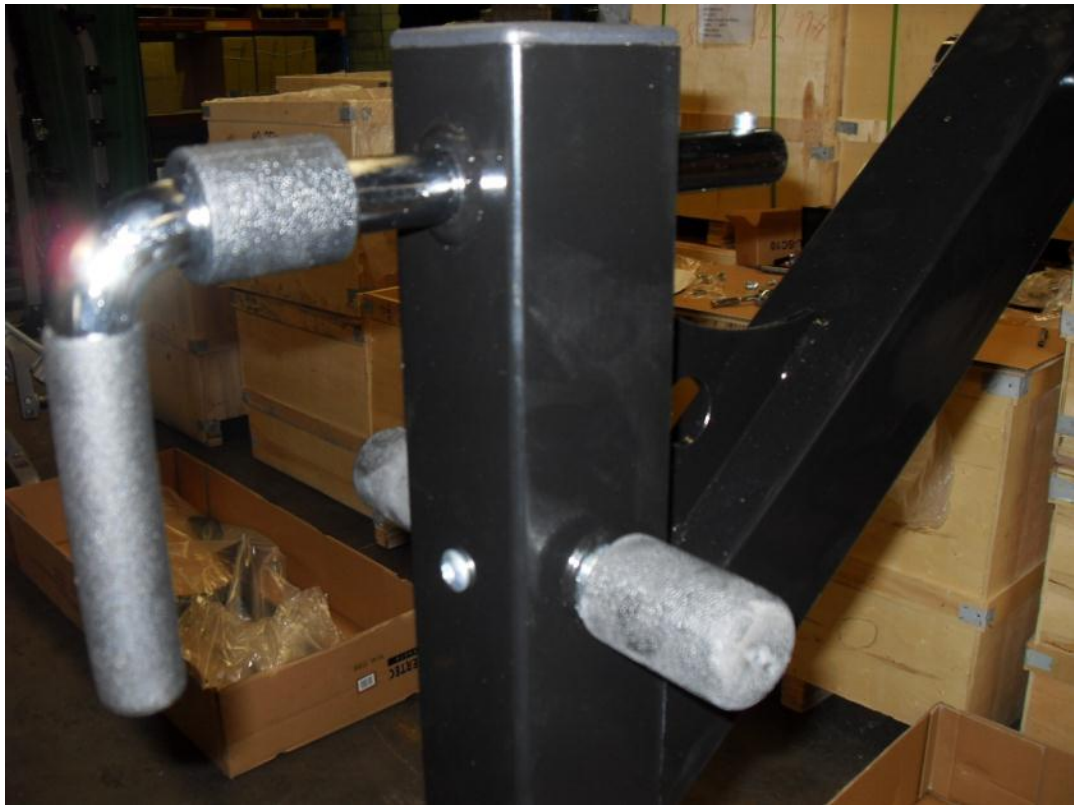



Assembly 4



Assembly 5



Assembly 6

